

ELEVATION

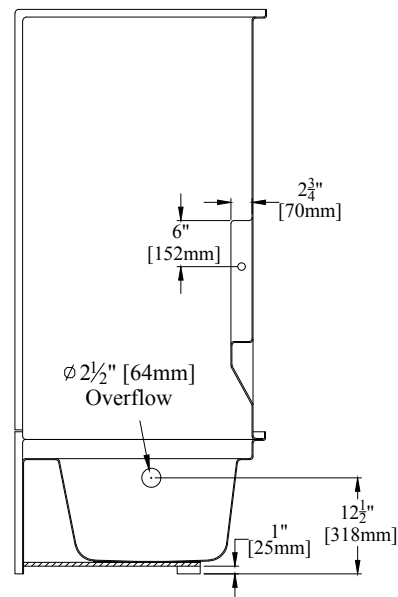

SECTION "A-A"

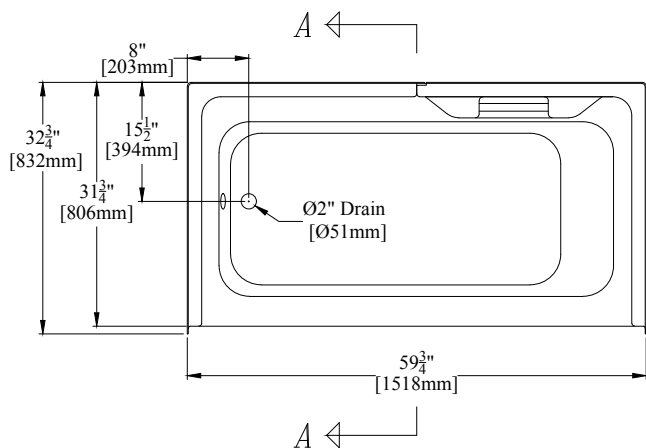

PLAN

59 3/4" [1518mm] 3-Piece Tub/Shower w/ Molded Shelving

Left Hand Version (9623LT) Shown

PRODUCT SPECIFICATIONS:

- * Product complies with NAHB, HUD UM-73A, and ANSI-Z124.1.2.
- * Product has a Class B fire rating as determined by ASTM E-84 test method.
- * Reinforced & slip resistant floor.
- * Integral 1" [25mm] nailing flange.
- * Factory installed 1" [25mm] clear acrylic towel bar. (not included on the MP version (MP9623L or MP9623R) of this product.)
- * Factory drilled 2 1/2" [64mm] overflow.
- * Door Opening: W-55 3/4" [1416mm]
H-57" [1448mm]
- * Bathwell Dimensions (At Top): W-51 1/4" [1302mm]
D-22 3/4" [578mm]
H-13 1/4" [337mm]
- * Bathwell Dimensions (At Bottom): W-43 1/2" [1105mm]
D-19 1/2" [495mm]
- * Bathwell Capacity (At Overflow): 44 Gal [167L]
- * Water Level (At Overflow): 9 3/4" [248mm]
- * All dimensions +/- 1/2" [12.8mm]
- * Clarion Bathware reserves the right to change design and/or dimensions.
- * Dimensions are the same for RE, MP, and all other versions of this model.

9623LT or 9623RT

59 3/4" [1518mm] 3-Piece Tub/Shower w/ Molded Shelving

Clarion
BATHWARE
44 Amsler Ave.
Shippenville, PA 16254

Phone: (814) 226-5374
Toll Free: (800) 576-9228
Fax: (814) 226-0730
www.clarionbathware.com

Signatures For Approval:

Customer: _____ Date: _____
Arch./Engr: _____

Quote #: _____
Job Name: _____

Dwg. #
9623LT or RT-CUT

Dwg. By: NMH
DATE: 4/4/2017

***** IMPORTANT NOTICE *****

Clarion Bathware reserves the right to change the design and/or dimensions of its products at any time. This drawing may have been updated since this publication was issued. Before placing an order for any product, refer to our website at www.clarionbathware.com to obtain the most current drawings for any products that you wish to purchase. Compare the date of revision of the drawing that you have with the one on the drawing on our website. If you do not have internet access, please call your sales representative or Clarion Bathware's sales department at 1-800-576-9228.